

INGRAM
Rollers

Rigid Pneumatic Wheel Roller **RP930**

Benefits:

- 6 Cylinder 152 HP turbo diesel engine
- Three Speeds: 0-6, 0-8, 0-12 mph
- Hydrostatic drive
- 30 Ton rigid frame
- Full wheel oscillation insures uniform densities
- Electronic displacement control (EDC) propel
- Side to side seat slide and 180° seat rotation
- Easily accessible engine bay under spring assist hood



Ingram keeps rolling across America

Photo Includes Optional Equipment

Benefits:

Ballast Capacity 280 cu. ft.

Weights

Empty	28,500 lbs
With water	46,800 lbs
With sand (dry)	57,500 lbs
With sand (wet)	63,300 lbs

Loads per Tire

Empty	3,166 lbs
With water	5,200 lbs
With sand (dry)	6,388 lbs
With sand (wet)	7,033 lbs

Engine Cummins, 6 cylinder turbo diesel producing 152 hp @ 2500 RPM. 12 volt electrical system; 63 amp alternator. Muffler. Two stage air cleaner with filter condition indicator and vacuator valve.

Wheels 11.00 X 20, 18 ply

Hydrostatic Drive The hydrostatic drive consists of a variable displacement piston pump and two planetary drive wheel motors. In this closed loop circuit the fluid is filtered through a 10 micron filter and returned to the reservoir passing through an oil to air heat exchanger.

Fuel System 50 U.S. gal. (124.9 liters)

Sprinkler System The 3 position "Memory Water" spray control gives the operator a helping hand.
Optional

Position 1 - Turns the system off.
Position 2 - Allows the spray system to operate continuously.
Position 3 - Automatically turns the spray system on whenever the machine is in motion, then turns it off when the machine is brought to a stop!

Speeds and Controls Infinitely variable speed forward and reverse 0-12 MPH. Speed, direction and dynamic braking are controlled by a single lever.

Standard Equipment Diesel engine. 18 ply tires. Cushioned adjustable seat. Horn. Seat Belts. Vandalism package. Water ballast covers. Neutral safety starter interlock. Parking brake starter interlock. Yellow Paint. Backup alarm. Engine shutdown systems. ROPs.

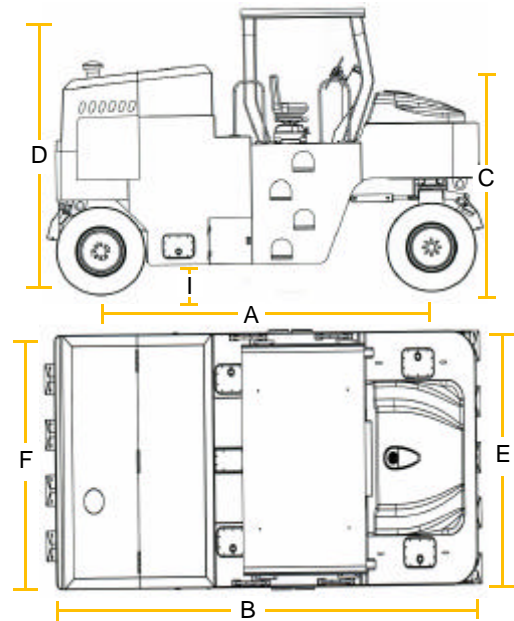

Dimensions:

without options

- A. Wheel base 156"
- B. Overall length 201"
- C. Overall height 111.5"
- D. Height w/ROPS 135"
- E. Rolling width 95.5"
- F. Body width 95.5"
- G. Outside turning radius 24' 5"
- H. Inside turning radius 13'
- I. Ground clearance 12.5"
- J. Tire overlap 15/16"

Optional Equipment:

- Beacon light
- Nylon scraper
- Skirt package
- Lighting package including:
 - Rear working lights (2)
 - Front working lights (2)
 - Turn signals
- Fog spray system (sprinkler system)
- Cocomats
- Cold weather start package

Sold & Serviced by:



Ingram Compaction, LLC
2823 Carlisle Ave.
Racine, WI 53404
Toll Free: 800-288-8629
e-mail: info@ingramrollers.com

www.ingramrollers.com