

Features

- 80 hp Cummins diesel engine
- Speed 0-16 mph
- Articulated steering provides for a tight turning radius and front to rear tire overlap through turns
- All wheel oscillation allows uniform compaction on uneven surface
- Electronic Displacement Control (EDC) propel
- Side-to-side seat slide with 180° rotation
- Easily accessible engine bay under spring assisted hood



Specifications:

Ballast Capacity61 cu.ft.

Weights

Unballasted	13,200 lbs.
Water	17,000 lbs.
Sand (wet)	20,500 lbs.
Steel	30,000 lbs.

Loads Per Tire

Unballasted	1,466 lbs.
Water	1,889 lbs
Sand (wet)	2,278 lbs.
Steel	3,333 lbs

Engine

Cummins B4.5NA four-cylinder diesel engine producing 80 hp @ 2200 rpm. 12 volt electrical system; 95 amp alternator. Muffler. Air cleaner with safety element, filter condition indicator and vacuator valve.

Tires 7.50 X 15, 14 ply

Hydrostatic Drive

The hydrostatic drive consists of a variable displacement piston pump and dual, two-speed wheel motors. Hydraulic fluid circulates through a closed loop system and is filtered through a 10 micron filter and returned to the reservoir after passing through an oil-to-air heat exchanger.

Fuel System 33 U.S. gal. (124.9 liters)

Sprinkler System

110 gallon capacity. System is pressurized to maintain a consistent flow of water to the spray bars. Three position spray control allows the operator to precisely control water flow to the tires.

Position 1 Sprinkler system is off.
Position 2 Continuous water flow to the tires
Position 3 Automatically turns on water flow to the tires when the machine is in motion and turns the system off when the machine stops moving.

Speeds and Controls

Infinitely variable speed forward and reverse. Two speeds: (0-8 mph) and (0-16 mph). Speed, direction and dynamic braking are controlled by a single lever.

Standard Equipment:

- Cummins water-cooled diesel engine
- 14 ply tires
- Cushioned seat with 180° rotation and side-to-side slide
- Seat belt
- ROPS
- Vandal cover
- Horn
- Back-up alarm
- Neutral safety and parking brake starter interlock
- 110 gallon sprinkler system
- Cocoa mats
- CE yellow paint

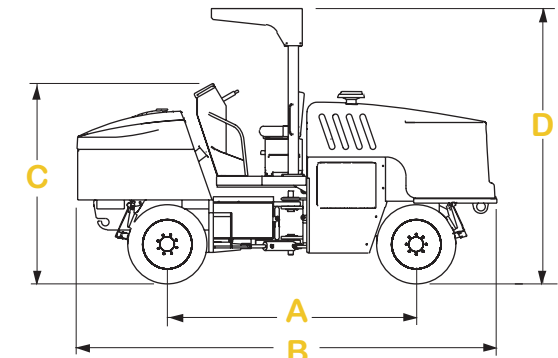
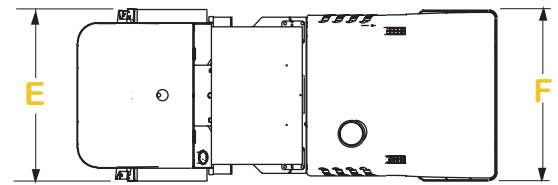

Dimensions: (without options)

- A. Wheel base..... 101"
- B. Overall length..... 170"
- C. Overall height..... 84"
- D. Height w/ROPS..... 112"
- E. Rolling width..... 68"
- F. Body width..... 64"
- Ground clearance..... 10.5"
- Outside turning radius..... 186"

Optional Equipment:

- Nylon scrapers
- Heat retention shields
- Michelin non-stick radial tires
- Beacon light
- Lighting package Including:
Front work lights (2)
Rear work lights (2)
- Turn signals/4-way flashers
- Sunshade for ROPS
- FOPS for ROPS
- Suspension seat

INGRAM
COMPACTION, LLC

1908 DeKoven Avenue
 Racine, WI 53403
 Ph: (262) 898-7338
 email: info@ingramrollers.com
 www.ingramrollers.com

Sold and Serviced by: